



**Aero-Pac<sup>®</sup>**

[www.aero-pac.com](http://www.aero-pac.com) • [info@aero-pac.com](mailto:info@aero-pac.com) • Belgium

**GENERAL AVIATION TOWBARS**

Aero-Pac Towbars stay on until you take them off



[www.aero-pac.com](http://www.aero-pac.com) • [info@aero-pac.com](mailto:info@aero-pac.com) • Belgium



## OUR ADVANTAGES

We stand for top quality products, client first service and worldwide on-time deliveries.

Every delivery comes with all certificates and export documents. Deliveries throughout Europe and the rest of the world are prompt and right on time.

BTV certified tugs.

World largest stock and productline.

Competitive pricing.

Close to EBKT airport, for demonstrations we have models available at the airport.



[www.aero-pac.com](http://www.aero-pac.com) • [info@aero-pac.com](mailto:info@aero-pac.com) • Belgium



## OUR FACTORY – ABOUT US

All our tugs are produced in our factory in Belgium.

we have modern CNC manufacturing equipment to meet any of your fabrication requirements. TIG, MIG, MAG, STUD, SPOT, Shearing, laser cutting, rolling, bending, Vertical mill, manual lathe.





www.aero-pac.com • info@aero-pac.com • Belgium

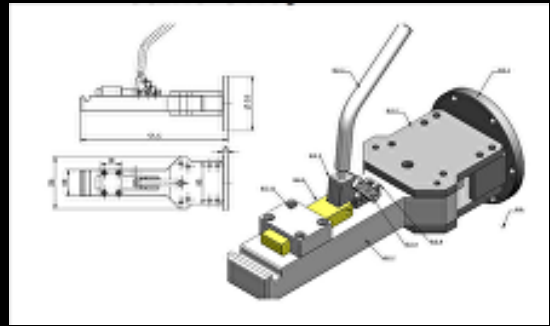

## OWN ENGINEERING

At Aero-Pac we strive to be better.

Having been in business for over 25 years, we continue to build upon our reputation of success.

We use 2D and 3D design software for modelling objects better and faster.

Upon request, we do tailor made towbars for special needs.

More than 500 towbars in stock.





www.aero-pac.com • info@aero-pac.com • Belgium



---

## NATO RECOGNIZED – PATENT

Aero-Pac parts and towbars and tugs are having NATO Stock Number, or National Stock Number (NSN) as it is known in the US, is a 13-digit numeric code, identifying all the 'standardized material items of supply' as they have been recognized by all NATO countries including United States Department of Defense. Pursuant to the NATO Standardization Agreements, the NSN has come to be used in all treaty countries.

Ask Aero-Pac for the NSN number for the stock-listed products.

Our NATO certified producer number : 1225070.

Our Patent number : Patent doc. 1024556 / F16B 23/00





www.aero-pac.com • info@aero-pac.com • Belgium

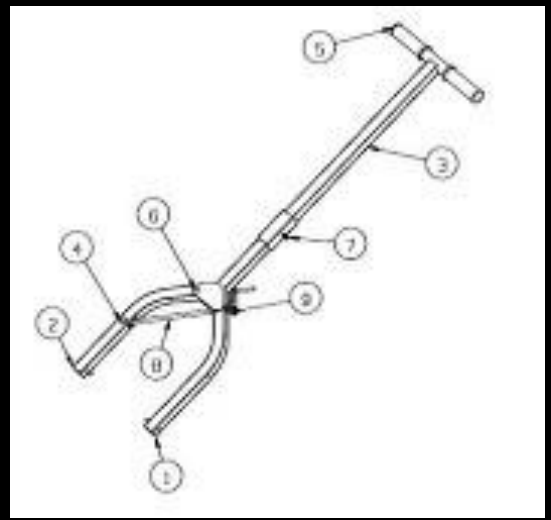

## FEATURES & BENEFITS

- Combination of steel used for durability.
- Foam rubber hand and lever grips standard.
- High shear quick release pins adjust length.
- Powder coating process resists scratches.
- Lifetime guarantee when used for the intended purpose.
- Made in the Belgium

## OPERATION

- Extend handle using a quick release pin.
- Open the jaws by pressing forward on the spreader lever.
- Position feet at the nose or tail wheel assembly.
- Release tension on spreader bar to lock handle.



www.aero-pac.com • info@aero-pac.com • Belgium

SR20/SR22 Towbar.

Locks with rotating handle.

For Secured towing.

Parts number : APTBSR22

(Standard color white or grey)

Foam rubber hand and lever grips standard.  
High shear quick release pins adjust length.  
Space saving design.

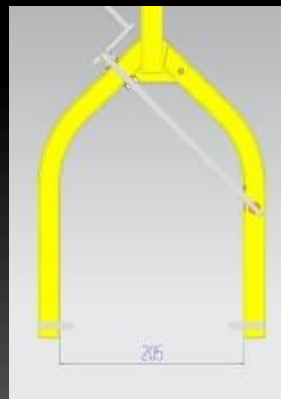





www.aero-pac.com • info@aero-pac.com • Belgium

- APTB235 Beechcraft - Baron, Bonanza, Debonair, Duchess, Duke, Skipper
- APTB236 Beechcraft - Musketeer, Sport, Super, Sundowner & Sierra
- APTB237 Cessna 150, 152, 162 Skycatcher, 172, 175, 177, 182 Also RV-4
- APTB238 Cessna 182 S (1996 and up) and T (2001 and up) models with long nose
- APTB239 Cessna 172RG, 177RG, 182RG & 210 series, Skymaster
- APTB240 Cessna Corvalis
- APTB241 Cirrus SR 20 & 22 Series
- APTB242 Columbia 350/400
- APTB243 Diamond DA20 Tow bar
- APTB244 Diamond DA40 Tow bar
- APTB245 Diamond DA42 Tow bar
- APTB246 Gulfstream American AA1 & AA5
- APTB247 Piper Comanche PA-24, PA-30 & PA-39 Also the Cherokee Six
- APTB248 Piper PA46 Hand Pull for dog-leg style gear, also fits Saratoga, PA-28R, Malibu, Mirage, Meridian
- APTB249 Piper PA-22 & PA-28 series (not PA-28R) Also, PA-32 Cherokee Six
- APTB250 Piper PA-28R Series - Hand Pull for dog-leg style gear, also fits Saratoga, PA-46, Malibu, Mirage, Meridian
- APTB251 Piper Seneca PA-34-200/220/220T
- APTB252 Vans - RV10
- APTB253 Vans - RV6A, RV7A, RV8A, RV9A, & RV12
- APTB254 tailwheel Scott 3200 & 3400
- APTB255 Mooney towbar
- APTB256 Rockwell commander towbar.
- APTB257 Trenidad towbar.

and lots more







[www.aero-pac.com](http://www.aero-pac.com) • [info@aero-pac.com](mailto:info@aero-pac.com) • Belgium



---

Universal towbar.

Stainless steel adapters on stock.

P/N : APUNIVTB



www.aero-pac.com • info@aero-pac.com • Belgium



---

General aviation towbar.

5 Tons – 10 Tons MTOW.

Quick change adapters.

P/N : APGATB





## Stainless steel Towbar

### Technical data

P/N APTBSLST



Optional storage bags available.



## Technical data

### Tailor made

- Shock absorber
- Comes in 4 parts.
- Aluminium
- Secured locking
- Carry handles.
- Reflector optional.
- Different tug hooks available.
- Corrosion free.





## Technical data

### Flate tire towbar

- Shock absorber
- Secured locking
- Carry handles.
- Reflector optional.
- Different tug hooks available.
- Corrosion free.

## Technical data

### Tire Dolly





## Hooks

### Technical data

- Galvano protection.
- No maintenance
- 1 person operable
- Secured locking.
- Shearpin protection optional.
- Electronic overstress protection optional.







www.aero-pac.com • info@aero-pac.com • Belgium



---

## CONTACT

AERO-PAC  
Industrialzone Strohof  
Kruisboommolenstraat 7/9  
8800 Roeselare  
Belgium

[www.aero-pac.com](http://www.aero-pac.com)  
[sales@aero-pac.com](mailto:sales@aero-pac.com)

+32.51.77.99.19