



Aero-Pac[®]

www.aero-pac.com • info@aero-pac.com • Belgium

TOW BARS FOR
COMMERCIAL AND MILITARY AIRCRAFT



www.aero-pac.com • info@aero-pac.com • Belgium



OUR ADVANTAGES

We stand for top quality products, client first service and worldwide on-time deliveries.

Every delivery comes with all certificates and export documents. Deliveries throughout Europe and the rest of the world are prompt and right on time.

World largest stock and Productline.

Competitive pricing.

Close to EBKT airport, for demonstrations we have models available at the airport.



www.aero-pac.com • info@aero-pac.com • Belgium



OUR FACTORY – ABOUT US

All our tugs are produced in our factory in Belgium.

we have modern CNC manufacturing equipment to meet any of your fabrication requirements. TIG, MIG, MAG, STUD, SPOT, Shearing, laser cutting, rolling, bending, Vertical mill, manual lathe.





www.aero-pac.com • info@aero-pac.com • Belgium

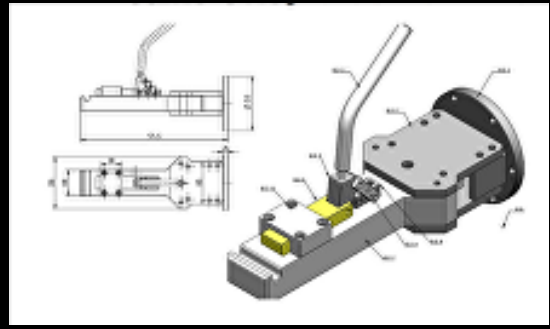

OWN ENGINEERING

At Aero-Pac we strive to be better.

Having been in business for over 25 years, we continue to build upon our reputation of success.

We use 2D and 3D design software for modelling objects better and faster.

Upon request, we do tailor made towbars for special needs.

More than 500 Towbars in stock.





www.aero-pac.com • info@aero-pac.com • Belgium

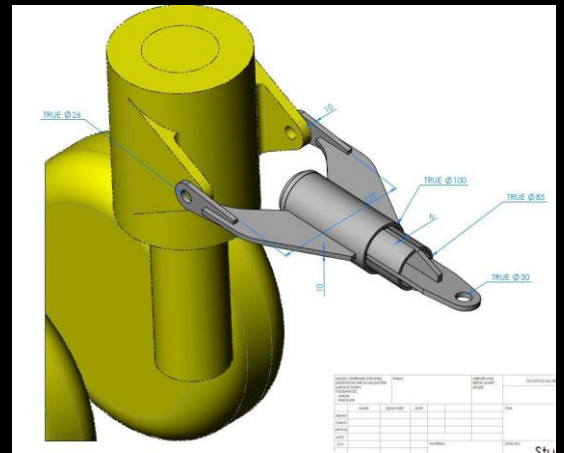

Aero-Pac ENGINEERING – 3D DESIGN

Some aircraft , helicopter need tailor made towbars.
Aero-Pac Engineering offer a bespoke design and fit service.

It takes us few working days for us to make a design of a tailor made towbar.

We are cost effective and aim to use standard solutions.

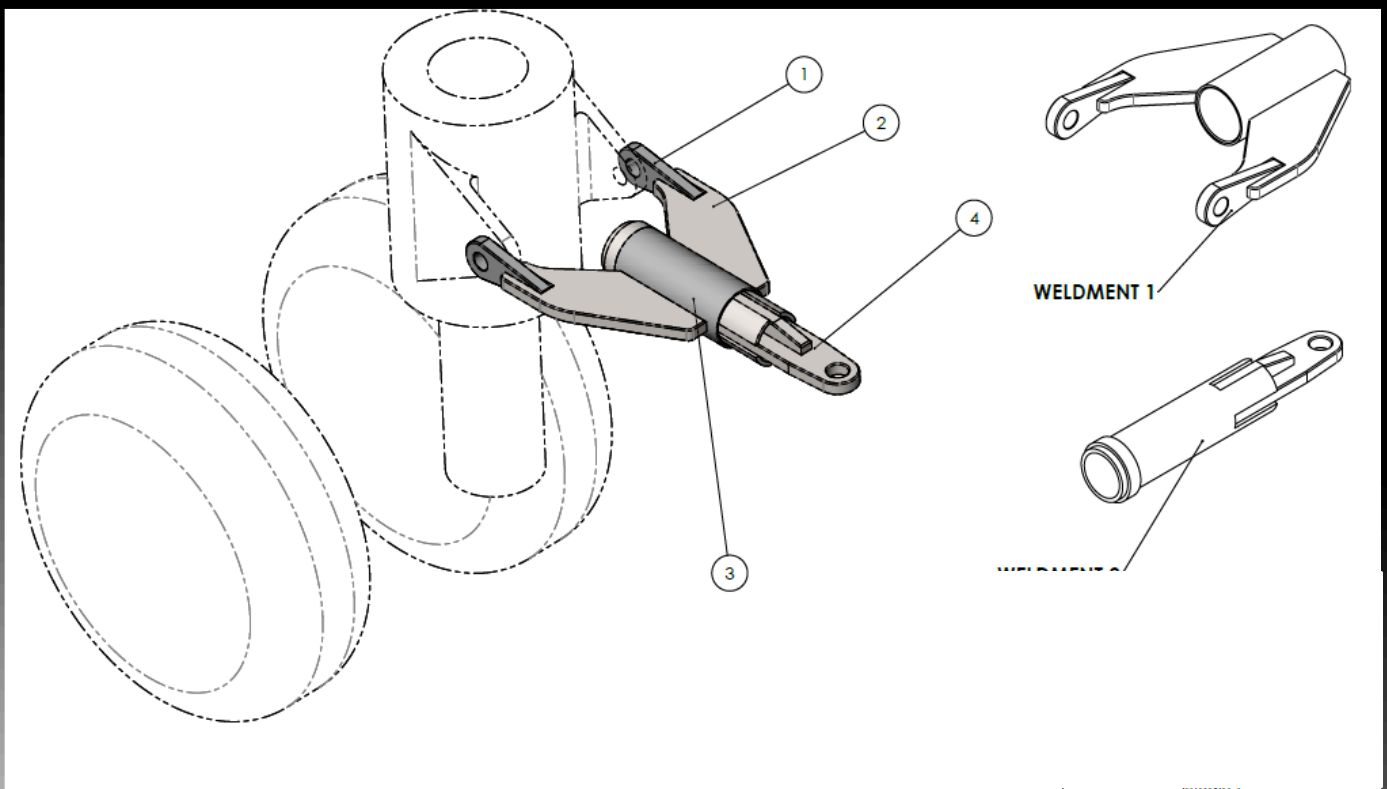



www.aero-pac.com • info@aero-pac.com • Belgium

FEATURES & BENEFITS

Combination of steel used for durability.

Foam rubber hand and lever grips standard.

High shear quick release pins adjust length.

Powder coating process resists scratches.

Lifetime guarantee when used for the intended purpose.

Made in the Belgium

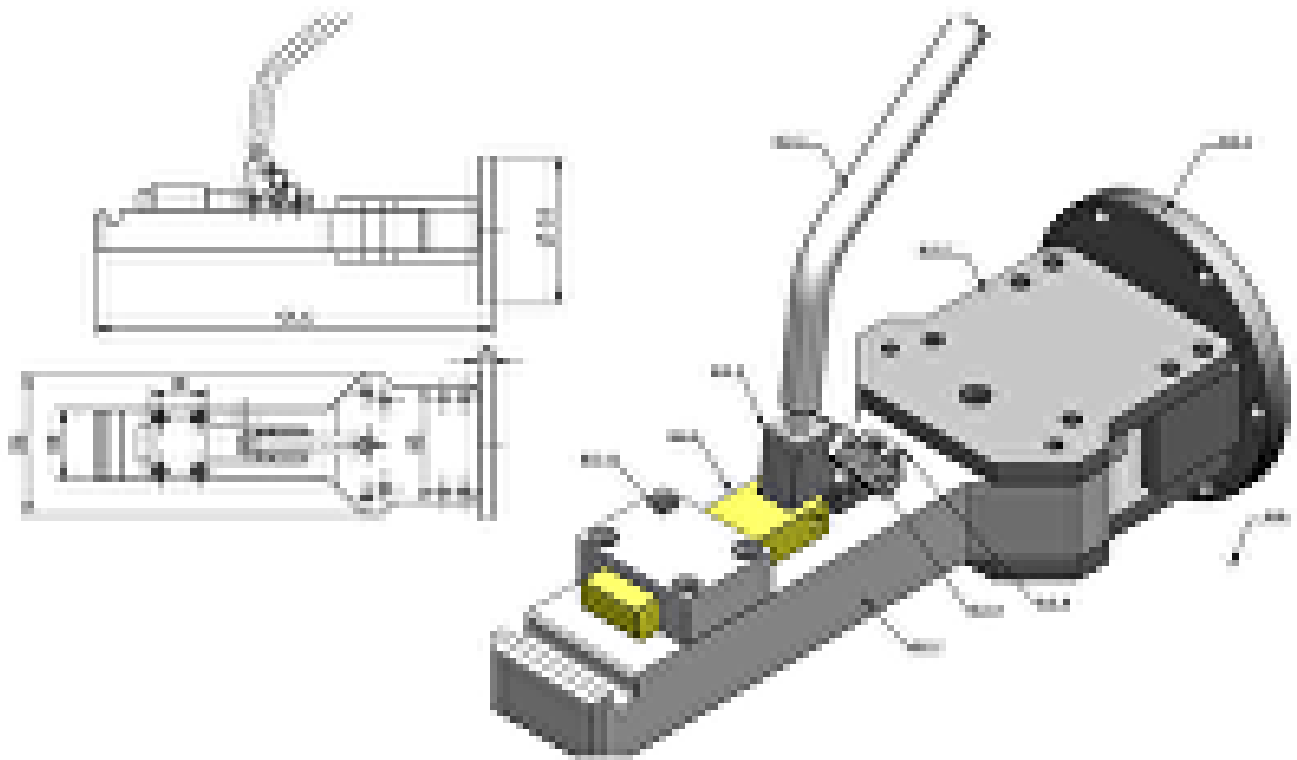



www.aero-pac.com • info@aero-pac.com • Belgium

Lifetime guarantee when used for the intended purpose.
Made in the Belgium

Aero-pac tow bars are designed in accordance to the requirements from aircraft manufacturers and the applicable norms and standards. They fit perfectly to operators needs. The free floating axle enables an easy connection to the NLG. The maintenance free hand pump with integrated spring and dead-man circuit guarantees high safety and outstanding accuracy. Customers all over the world trust in the outstanding quality made in Belgium.

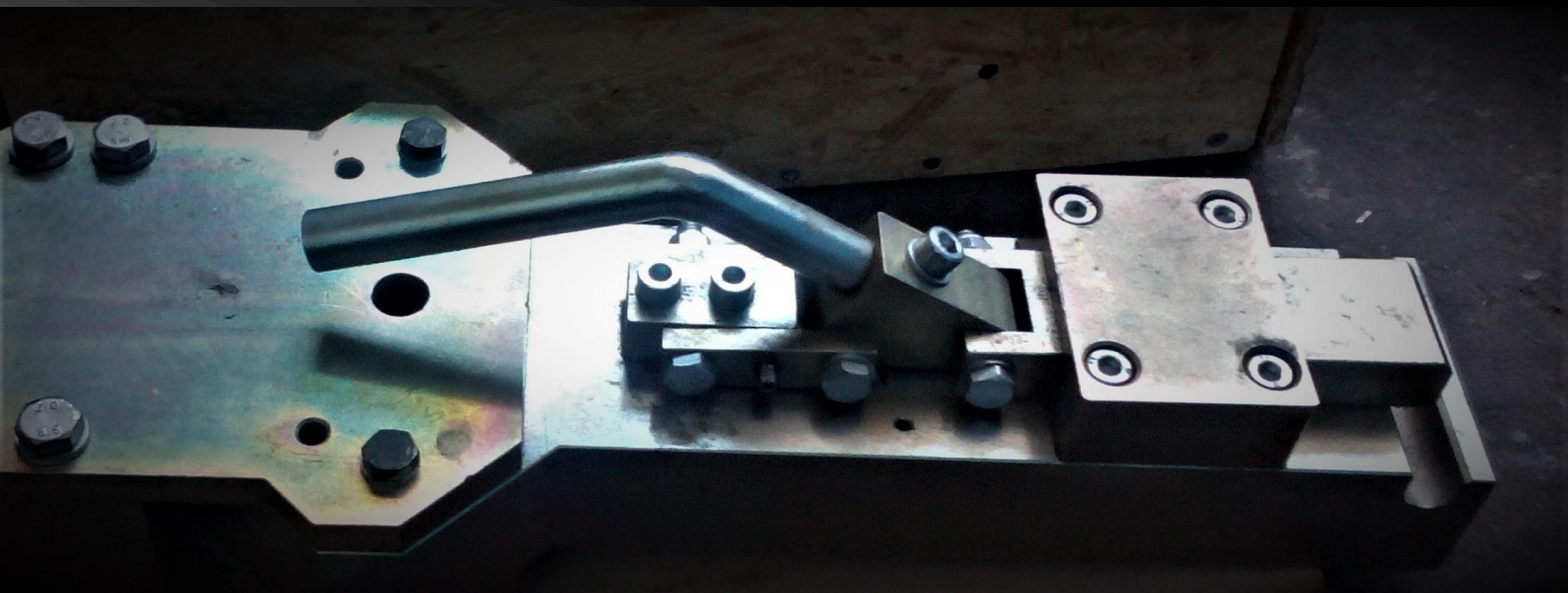





Quickchange Towbar A320 / B737

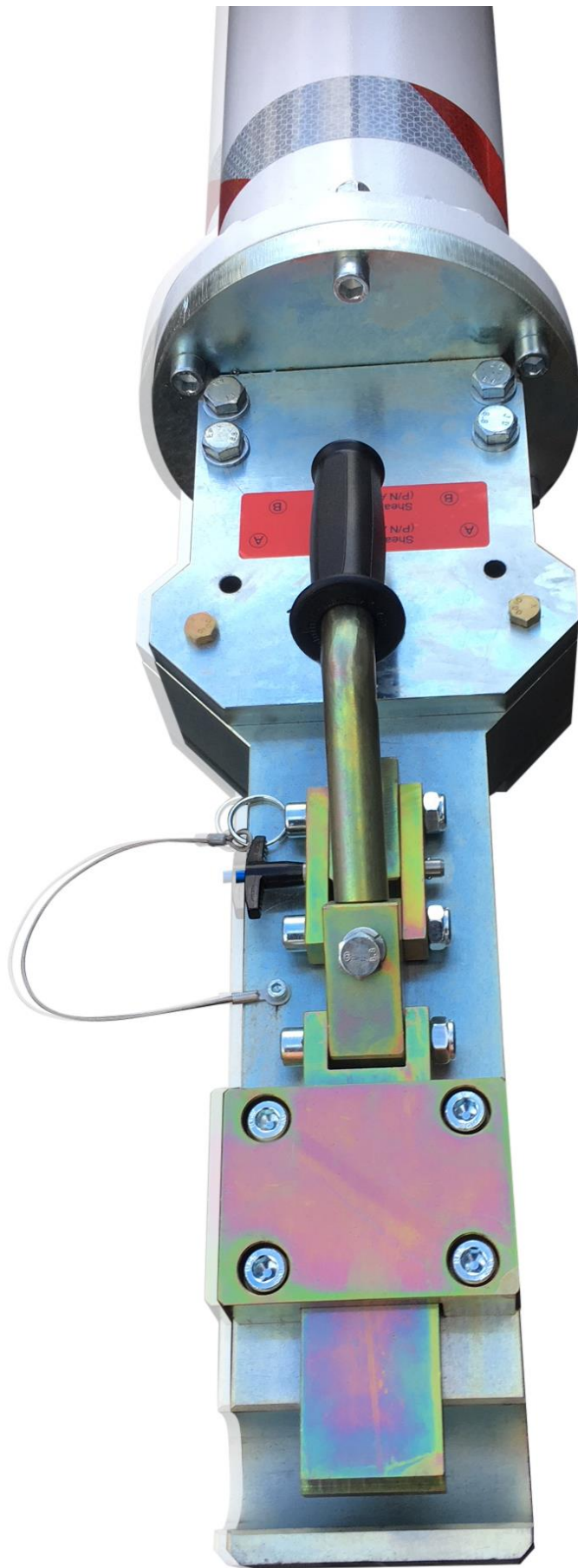





Widebody Towbars

Aero-Pac[®]

www.aero-pac.com • info@aero-pac.com • Belgium



www.aero-pac.com • info@aero-pac.com • Belgium

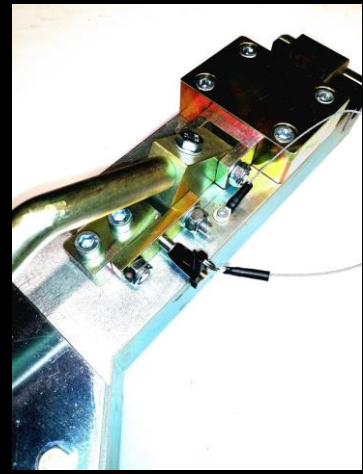

NATOHOOK TOWEYES



www.aero-pac.com • info@aero-pac.com • Belgium





www.aero-pac.com • info@aero-pac.com • Belgium



UNIVERSAL TOWBAR 5 TONS



www.aero-pac.com • info@aero-pac.com • Belgium

Rigid tow head

- Modular design of tow bar enables interchangeable tow heads
- Multi-purpose applications
- Easily interchangeable through

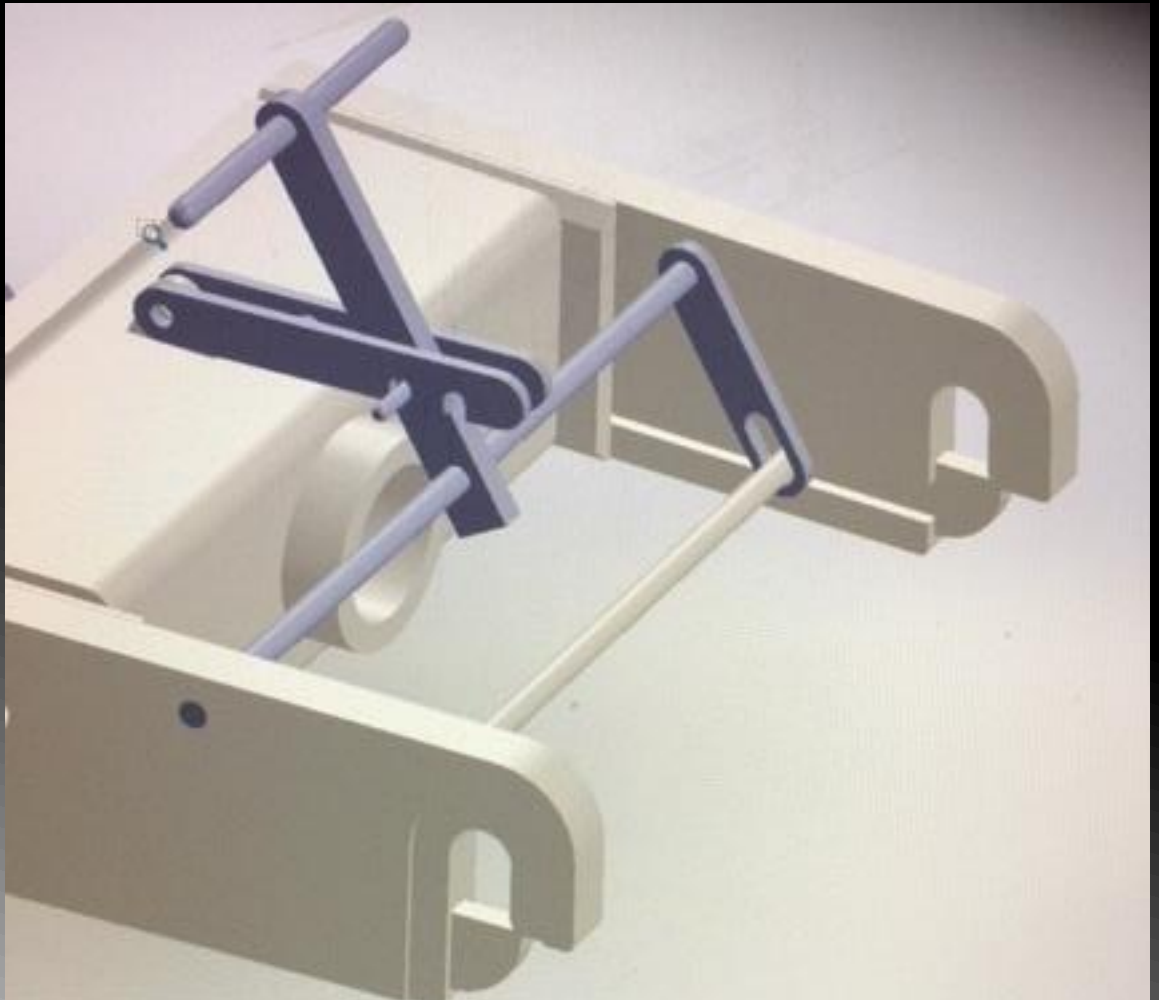



www.aero-pac.com • info@aero-pac.com • Belgium

Aluminium Fly away towbars.

Split aluminum bar (two pieces) and head without wheels.

Heads available for different aircraft.





www.aero-pac.com • info@aero-pac.com • Belgium

All tow bar components such as tube, undercarriage, tow eye etc. are bolted rather than welded. This modular concept provides the highest flexibility and simplifies equipment maintenance radically.

Aero-Pac[®]

www.aero-pac.com • info@aero-pac.com • Belgium



Military Towbars , available from stock.





www.aero-pac.com • info@aero-pac.com • Belgium

Pin locking heads.

FEATURES & BENEFITS

Combination of steel used for durability.

Foam rubber hand and lever grips standard.

High shear quick release pins adjust length.

Powder coating process resists scratches.

Lifetime guarantee when used for the intended purpose.

Made in the Belgium





www.aero-pac.com • info@aero-pac.com • Belgium

NATO HOOK





www.aero-pac.com • info@aero-pac.com • Belgium

Durable lifting system.





www.aero-pac.com • info@aero-pac.com • Belgium



Regional towbars



www.aero-pac.com • info@aero-pac.com • Belgium



Widebody towbars.



www.aero-pac.com • info@aero-pac.com • Belgium



Airliner towbars



www.aero-pac.com • info@aero-pac.com • Belgium



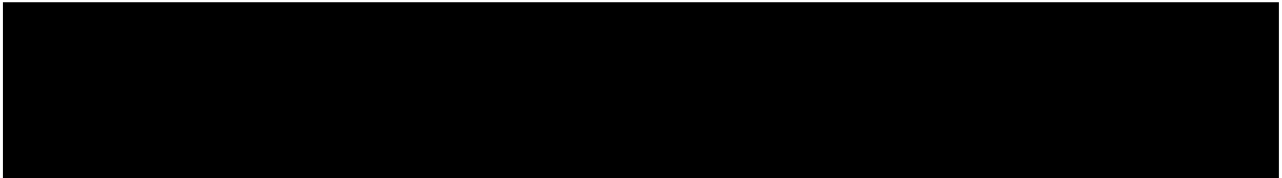

Technical data

Flate tire towbar

- Shock absorber
- Secured locking
- Carry handles.
- Reflector optional.
- Different tug hooks available.
- Corrosion free.





Technical data

Tire Dolly





Hooks

Technical data

- Galvano protection.
- No maintenance
- 1 person operable
- Secured locking.
- Shearpin protection optional.
- Electronic overstress protection optional.





www.aero-pac.com • info@aero-pac.com • Belgium



CONTACT

AERO-PAC
Industrialzone Strohof
Kruisboommolenstraat 7/9
8800 Roeselare
Belgium

www.aero-pac.com
sales@aero-pac.com

+32.51.77.99.19